



DATCOM CURVO ROPEWAY FOR URBAN COMMUTATION

SHEKHAR CHAKRAVARTY

Conveyor & Ropeway Services Pvt. Ltd., 75C, Park Street, 6th Floor, Kolkata -700 016,

*Corresponding Author: crs_pl@yahoo.co.in, Ph. No. +91 (33) 2229 5990, 2217 6779, Tel: +91 98300 52094

Abstract

Years of design efforts and simulation, a special non-linear CURVO ropeway system, operating over arterial metro city roads, has been developed, with specific aim to contain emission, road casualties, health hazards and huge fuel subsidy. The paper presents a noble application of the aerial system, named "CURVO ROPEWAY" to highlight its huge potential in future years.

1. Introduction

Curvo Ropeway concept for urban commutation generated from concerns of

- I. Pollutive, vehicular (CO) emission, & consequent health hazards.
- II. Alarming Casualties on roads. and
- III. Swelling traffic jams, causing tension and enormous loss of time.

Presently, fuel engine driven vehicles, constitute the main transportation force, requiring considerable growth in infrastructures, in city roads and flyovers, for accommodation of vehicular spaces, resulting in ascending carbon emissions, lung related diseases which are assuming an alarming level, particularly, in children. Plus, casualties in city roads are going up by leaps and bound.

The aforesaid ills have remained a matter of concern to thinking people, for their new

generation, breathing the CO contaminated dirty air, and also exposed to chaotic city traffic. Significant solution, so far, have not been discerned, although pollution free Metros, LRTs, APM and so on, are in existence.

With experiences in aerial systems, attempts for their use in cities were made, but, its inflexibility blocked its entry, so far. Ropeways, generally, follow point to point straight alignment along linear corridors. Provisions of a horizontal deviation needed large space and complicated arrangements, for implementation in urban areas, which are congested. Thus, Linear Ropeways did not gain popularity in commuter transport in cities, for its inflexibility in non-linear routes. A few Ropeways built, were all on straight alignments. But a hold on further induction of vehicular load on existing city road spaces, could be achieved with overhead commuter services only.



Average annual reading (2007-08) at manual air quality monitoring stations in Kolkata, India

Present Ropeway Builders are unable to negotiate non-linear alignments, while moving at line speed, and without detachment from the rope.

It was, therefore, a long felt need to develop the facility in ropeway system, which is adapted to negotiate bends over city roads, in particular, and on congested locations and all other locations in general with ease, and follow the existing road routes, in an overhead manner without interfering with the road space, the traffic movement, vehicular traffic, and the pedestrian movement as well, on the kerbs. In pursuance to such need, there was also a need for such carrying facility, which is safe, sound and pollution free, (both emission and noise), and accident free, having automatic operating Device, instead of multiple human control behind the wheels, for vehicular systems. Thus, movement of Aerial Ropeway facility along a non-linear route has enormous potential in cities, in particular, and in congested places, to serve as a safe, pollution free and economic mode of mass transport.

The development of Curvo Ropeway meets the aforesaid long felt need, as it is non-linear, and unique in Ropeway system. With above

referred features, and ability to negotiate serpentine routes of existing roads, necessary clearances of Curvo system from statutory Authorities should be considered to be in position, not needing the statutory NOCs (No Objection Certificate) etc.

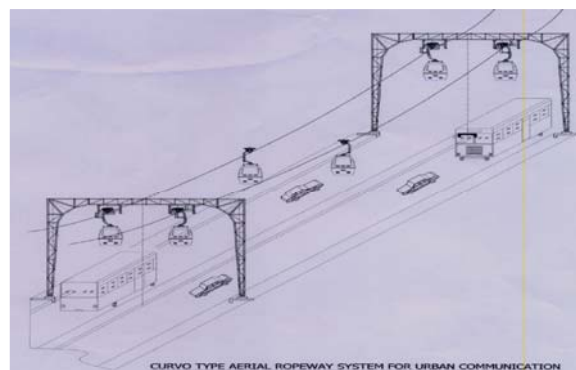

The system along its alignment will have Rope supporting portal frames, normally spaced at 90-100 mtr. Sleek frames along with colourful cabins on line will not disturb the oecology much. The system's superimposition on overhead Metro & Flyover structures, illustrated, will highlight, how much relief could be achieved compared to the concrete structural interference with oecology in the other systems.

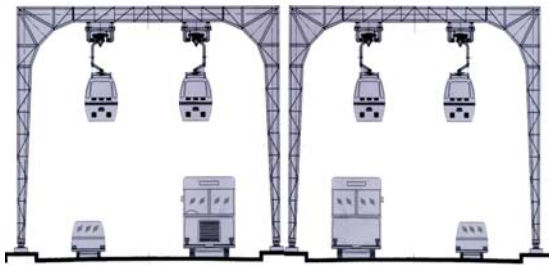

Metro Structure



Flyover Structure

2. SYSTEMS CONSTRUCTION

Normal Detachable Grips, used on Ropeways, presently, are illustrated in Sketch. They comprise horizontal Grip Structures equipped with vertical actuating device for Locking and Unlocking operations at Terminal and Intermediate stations.

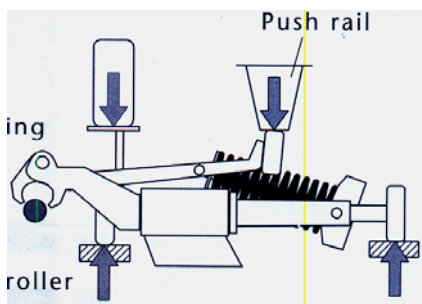

Conventional Grip

Curvo Ropeway system with unique non-linear feature has vertical Grip Structures, unlike others, and equipped with horizontal actuating device for Locking and Unlocking of the said Grips.

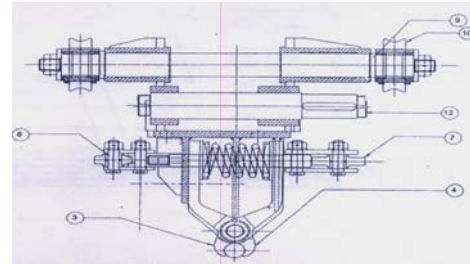

Curvo Grip

The crux of the CURVO Ropeway's invention /development lies in designing the Gripping Device of the rope, in its vertical structure with respect to the rope, along with horizontal actuation of gripping means, and rendering it possible to shift centroid of suspended Cabin / Carriage, essentially required to negotiate the horizontal curve at line speed, keeping the grip structure clear of the Battery Rollers, whose main function is to provide horizontal support to the tensioned rope negotiating the curve. This could be done with relational adjustment of levels of the rails supporting the two wheel bogies on either side of the rope effecting changed suspension, and relief of the Rope on the Battery Roller system.

Depending on city configurations, the Curvo lines should be able to cross each other.

A Comparative Statement of the inherent features of both Auto Vehicular and CURVO Ropeway systems in urban commutation is given below. It highlights the attractive features of CURVO System.



COMPARATIVE URBAN COMMUTATION SYSTEM

SI	Vehicular Road Transport	Aerial CURVO System Transport
1	The systems operate on road surfaces with the help of fuel engine prime movers	The system negotiates aerial routes with electric prime movers. Relieves road surfaces.
2	Commuter movement capacities , dependent on road widths, traffic lights, congestions, etc.	Commuter movement capacities , depending on road width, could be 2000 pph and 4000 pph per road stretch
3	Multiple human Drivers behind the wheels are responsible for system control . Proneness to accidents from Drivers abilities, and caution levels, is high.	Automatic electric device for system control . Human element hardly involved, except watch through CCTV and use of buttons, if necessary for stops and starts during operations.
4	Very prone to traffic congestion and disruption.	Cabins are automatically spaced. Question of congestion do not arise.
5	Pollution & Carbon Emission is HUGE	Pollution & Carbon Emission is NIL
6	Considerable contribution to Global Warming	Almost NIL Contribution to Global Warming
7	Huge fuel subsidy from Exchequer.	No fuel subsidy from Government needed
8	Nearly 400 casualties/ day from urban road accidents .	Expected NIL casualties from urban movements.
9	New facilities in the form of flyovers cost US\$225.00 Millions/ km.	For Commutation capacity of 2000 pph approx. US\$27.00 Millions/ km. investment . For 4000 pph. approx. US\$50.00 Millions/ km.
10	Existing road routes have hardly any scope for expansion.	Will occupy 2.0 m ² land space on the kerb for each column support at approx. 90 / 100 M spacing
11	New facility with flyovers will take a period of 3/4 years for gestation on the same route.	Period of construction for a 4000 pph system, over a stretch of approx 4/5 km, 12/15 months may be considered
12	Occupies 60 to 70 % of road surface during peak hours Buses, Cars and Autos.	Will not disturb road surface



SI	Vehicular Road Transport	Aerial CURVO System Transport
13	Health hazards and accidents. Children at tender ages suffer from Asthmatic and respiratory problems. Cheap version of private cars will aggravate.	On CURVO aerial system, there is no emission, no contribution to health hazards and accidents
14	Maintenance needed to keep road surfaces devoid of damages, potholes and craters	Routine preventive maintenance during night hours. Annual maintenance cost, per km basis, less.

3. Transportation Potential

Curvo system, is similar to conventional detachable Monocable Ropeway, other than its unique CURVO feature. Transport capacity of 2000-2500 pph has been considered per line. On wider roads, particularly, on dual carriage way with Divider, as shown, transport capacity 4500 pph in each direction could be achieved. All urban roads are wide, where CURVO system overhead, would be able to transport 4500 commuters per hour in each direction.

4. Speed & Power Consumption on Curvo Ropeway

Line speed of Curvo System assumed to be 4 M/s, equivalent to 14.5 Km/hr.

With very slow speed over boarding / deboarding areas at stations, average travel speed would be around 3.5 m/sec or 12.6 km/hr on the CURVO system.

As for power, over 5.0 Km Drive section, installed power need, will be around 175 KW. Thus on a total Curvo network of 250 Km in a city the maximum consumption will be 8.0/9.0 MW, if operated at full load, whereas power consumed by the city Auto Vehicles would be

equivalent to over 500 MW, to negotiate the same distance and commuter load.

Commuter conveyance capacity even upto 100,000 passengers per hour, in each direction, could be achieved in a city, with CURVO Ropeways over multiple roads, thus providing enormous potential to contain the increasing imposition of auto vehicular system. Layout of Kolkata, an Indian metro city, in Sketch, shows approximately 30 wide roads, leading towards the city's commercial Centre, which could have overhead CURVO's on them, and generate moving capacity of more than 200,000 commuters per hour, equivalent to more than 2000 bus loads, which, normally, would consume not less than 50 K-litres of gasoline during a day, giving rise to enormous carbon emission alone, not to speak of other hazards and losses to exchequer. Some Curvo routes, in red, have been shown superimposed on Kolkata map.

5. Route

CURVO Ropeway is a continuous moving system between two terminals. Its route will be



flexible, depending on the city road routes, wherever it will be selected for implementation. There could be multiple lengths of routes, depending on the decision of the city Authority and density of commuter population. The length of routes would vary.



6. Average Vehicular Speed in City/Metro

Studies on various Metropolis, in India, considering various factors, indicates average vehicular speeds, citywise, as below :-

Delhi	9.0 km/hr
Kolkata	7.0 km/hr
Mumbai	9.0 km/hr
Chennai	8.0 km/hr

All the above speeds are considerably lower than the average speed on CURVO system referred, which is 12.6 km/hr.

7. Intermediate Station

Intermediate Station considered to be spaced at 750 mtr. approx. to facilitate the approach aspect of the local people around the Stations, which will be elevated type, with necessary boarding / deboarding platforms with leads to elevator lifts for ascending / descending

purposes. Ticket counters at station to have assigned corridors leading to the lift in enclosed area.

8. OPERATION

At the station, an incoming cabin suspended from the vertical grip will get detached from the moving rope, decelerated, and taken to the boarding / deboarding area, preceded by automatic opening of cabin doors. Boarding / deboarding by commuters will take place, while the cabin will be on move at a very slow speed with its doors opened. Once boarding will be over, cabin doors will get automatically closed at a prefixed location, followed by its discharge to the locking area, where the grip along with the cabin after having attached with the moving rope will proceed on the line at the designed line speed towards next station. Similar operation will be there on the other side of the station, also. Movement of commuters on the stations will be controlled, so that there is no interference with moving cabins.

9. TERMINAL STATION

Terminal Stations of a section will be equipped with a Drive at one end, and a tensioning device by hydraulic means, at the other. The Drive and Tension Station, will be equipped with necessary provision for boarding/ deboarding too and elevating of the commuters to the station platform areas, as in case of Intermediate Stations.

Operation of the CURVO system, section wise, would be from the Drive Station Control



Room. CCTV facility will be there, at each station to monitor smooth operation of the system, and Drive stations to have monitors for all the stations, under its control. The operational sections will be interlocked so that, in the event of any unlikely stoppage, the adjoining section would also stop, and then start, simultaneously.

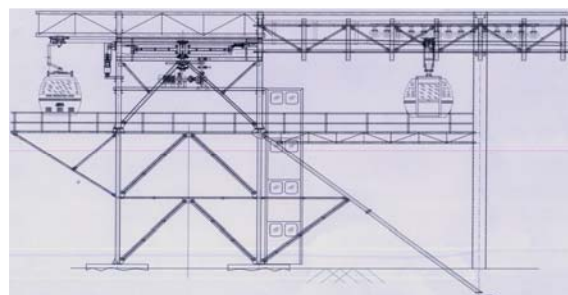

Control of the CURVO system will be with the control room operators, only.

PROTOTYPE SYSTEM

A prototype full scale CURVO system has been designed, and construction is nearly complete, over a short stretch, accommodating two terminal stations, two intermediate angular modules, which is illustrated in Sketch. It is a full size operating model accommodates buses and trucks, negotiating under it along the stretch. Passenger cabins will travel with rope on system to demonstrate the CURVO feature.

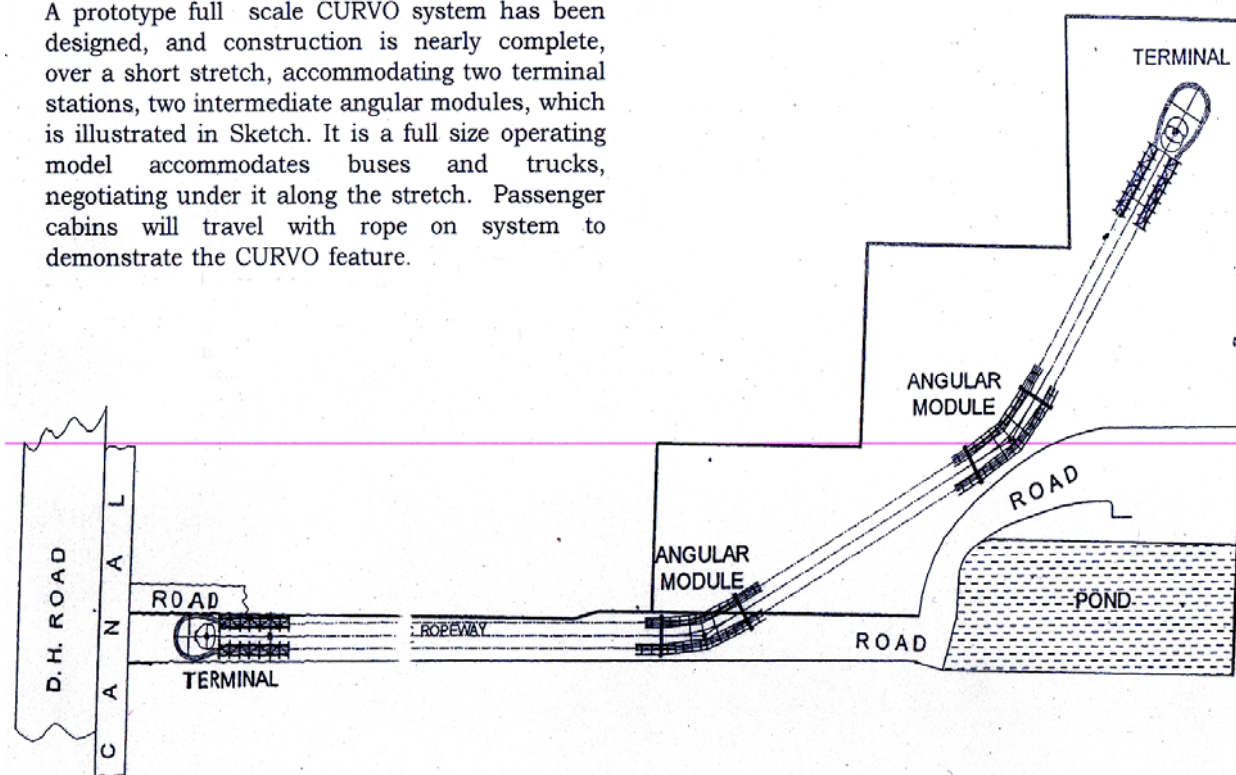

10. RISK ELEMENT

CURVO Ropeway like any other passenger ropeway, whether in Alps, Colorado, Denver and Whistler Mountains and other places in Asia, are so designed and constructed that there will be hardly any element of risk, which could result in casualties, because of the safety features incorporated at all possible points, which might result in any type of abnormal features, and the system is such designed, that they will be

promptly detected and reflected on the system for emergency stoppages.

A press report relating to casualties from vehicular traffic states that, in Indian, urban cities alone, constituting 8 to 10 of them, annually, 130,000 is the number of casualties.



In CURVO system, it is beyond imagination because, accidents on account of the following factors associated with vehicles can be completely ruled out in CURVO System :-

- i. Fault of vehicle drivers
 - ii. Fault of other vehicle drivers
 - iii. Fault of pedestrians on roads
 - iv. Factors related to speeding vehicles,
- whereas in CURVO, carriers travel at constant speed, and spaced equally

- v. Poor conditions of road surfaces and risks on account of potholes and craters
- vi. Lack of discipline in individual drivers, mainly Buses, Taxis and Autos.

Thus, CURVO Systems have the potential of opening up a new chapter for a safe and comfortable urban aerial commutation, all over.